

# Casemaking SYSTEM



## ODM CASEMAKING BUILT FOR TWO

# CASEMAKING MADE SIMPLE!



### SPECIFICATIONS & TECHNICAL DATA:

### CASEMAKING SYSTEM™ BUILT FOR 2 OPERATORS

Maximum Cover Size:	18" x 30" (Open)
Minimum Cover Size:	4" x 4" (Closed)
Output (per hour):	120 to 200 covers
Floor Space:	42" x 132"
Net Weight:	750 lbs.
Power Required:	
<b>Spreader:</b>	115 Volt, 5.9 Amps 60 Cycle, 1/3 H.P.
<b>Squeezer:</b>	115 Volt, 4.6 Amps
<b>Stomper:</b>	Air 70 PSI

### STANDARD EQUIPMENT for CASEMAKING SYSTEM™ includes SPREADER, SLIDER with LIGHT BOX, STOMPER & SQUEEZER:

- **Spreader™** – Top side gluer comes equipped with an 18" glue roller.
- **Slider™** – Case gauge arms open to a maximum of 4".
- **Built-in Light Box** – Ideal for accurate registration of pre-printed covers. Increases production output.
- **Stomper™** – Utilizes an external air source of 70 PSI. Machine cover size up to 30" width. Larger units can be custom made.
- **Squeezer™** – Rotary press will accept materials up to 18" in width by any length.

### DIMENSIONS: FRONT VIEW

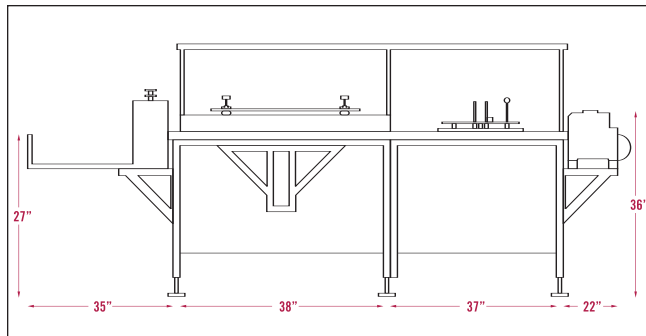

### SIDE VIEW

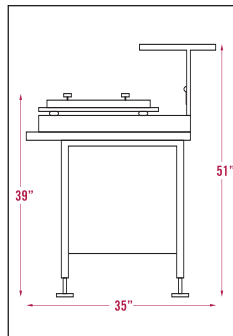

### OVERHEAD VIEW

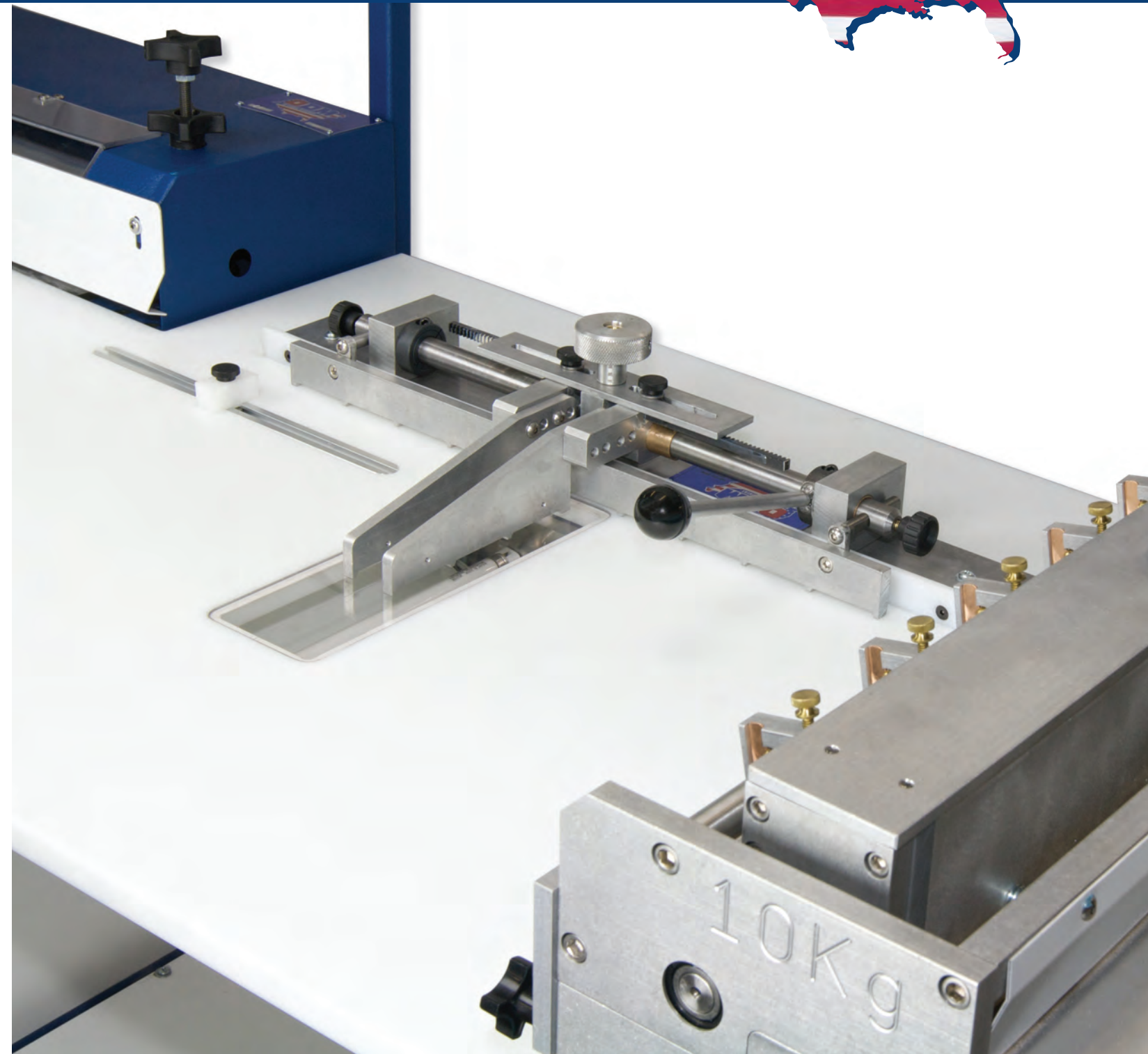
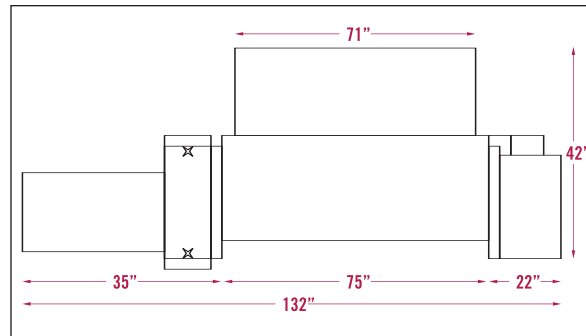

### FINISHED HARD COVER BOOKS

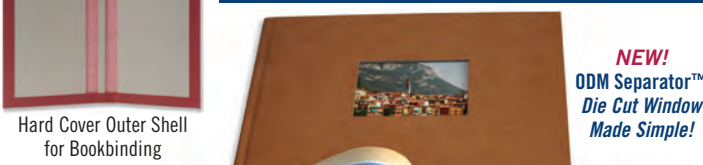

ODM FREE TECH SUPPORT: 908-351-6906

150 Broadway, Elizabeth, NJ 07206 • Tel: 908-351-6906 • Fax: 908-351-7156 • www.ODMachinery.com



# BOOKBINDING MADE SIMPLE WITH THE ODM CASEMAKING SYSTEM!

With the advent of on demand printing technology the book publishing, digital imaging, and photo-finishing industries has been changed forever. The initial solution for on demand books was a simple perfect bound paper back. Over the last few years, the on demand book market has evolved with many seeking a real book, that is, a hard cover edition that will last for generations to enjoy. It is for these reasons that On Demand Machinery

choose to design and market a complete line of on demand hard cover binding machinery. Never before has the hard cover case binding process been so simple. ODM has broken down the process into four easy steps that are simple to master. **The first process is the Casemaking System™ which includes: the Spreader™, Slider™, Stomper™ and Squeezer™.** ODM equipment can help you begin to produce your own hard cover books.



**Finished hard cover goes through the rotary press.**  
The Squeezer rotary press will accept materials up to 18" in width by any length. The machine comes with a safety latch guard and delivery table. Squeezer rollers are adjustable for both pressure and gap opening.



**All four sides of the hard cover are turned-in.**  
The Stomper air operated turning-in machine is activated by depressing a foot switch. The climbing action of the turning-in bar insures a tight corner wrap. Materials from leather to library buckram can easily be turned-in with the Stomper. Maximum cover size is 30" wide. Larger units can be custom made. The machine utilizes an external air source of 70 PSI.

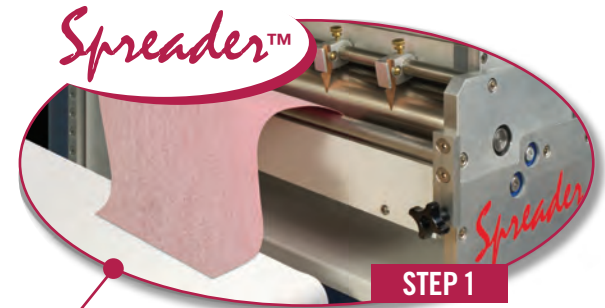

**Cover material goes through the top side gluer.**  
Spreader top side gluer comes equipped with an 18" glue roller. The cold PVA adhesive is placed in an easily removable glue reservoir. The thickness of adhesive is easily adjusted by a scraper blade and is powered by a 115 volt, 60 cycle, 1/3 HP motor. The machine eliminates the need for the operator to **flip over** the glued cover material as with traditional bottom side gluers. This unit quickly disassembles enabling for a fast and easy clean up.



**Spots and aligns hard cover boards in position with sliding table case gauge.**  
The Slider case gauge makes the positioning of board material a snap! The arms will open to a maximum of 4". The unit also comes equipped with an adjustable side guide and arm spacer kit for different joint gaps.

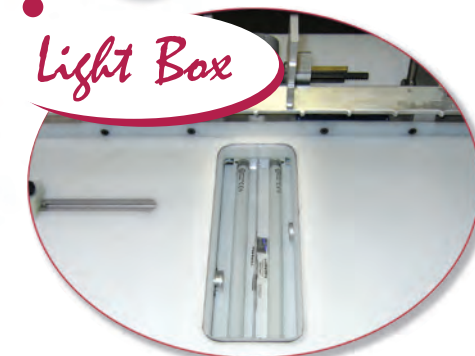

**NEW! Built-in light box increases accuracy.**  
The light box has a very specific purpose, when aligning pre-printed covers, you do not need to use the slide guide. Just simply center the title on the scribed line and the type lines up perfectly on the spine. While it does increase production, the main reason is for accuracy, as all printing machines have some "bounce" in the registration.

**Ideal for hard cover bookbinding, photo books, turned-edge binders, menu and padded covers.**

During casemaking, the hard cover is produced that becomes the outer shell of the book. First start with a book cloth, or printed material. The operator sends the material through the topside gluer (Step 1 - Spreader), where a uniform coating of PVA cold adhesive is applied to the sheet. The freshly glued cover material is inserted into the sliding table case gauge (Step 2 - Slider) allowing the operator to accurately position all three cover boards that comprise the book cover. Once the cover boards are aligned, the operator inserts it into the air-operated turning-in machine (Step 3 - Stomper) where all four sides of the cover material are turned-in (wrapped around the edges of the cover boards). During the final step of casemaking, the finished cover is fed through the rotary squeeze press (Step 4 - Squeezer) where the cover is pressed to insure the cover material and boards are laminated.



Configured for two operators...



Produce 120 to 200 covers per hour!